

QUARTER-TURN STRAIGHT SUPPLY STOP

129 SERIES

SPECIFICATION

Sioux Chief 129 series quarter-turn supply stops shall be used as a means of controlling pressure water connections to plumbing fixtures for the purpose of being able to turn off flow for repairs or emergency situations.

INSTALLATION

Attach to pressure piping as prescribed by inlet connection on stop valve. Connect supply hose of desired configuration to outlet of supply.

MATERIALS

- Valve body:** no lead brass
- Ball:** chrome-plated brass
- Ball seats:** polytetrafluoroethylene (P.T.F.E.)
- Handle:** zinc
- Stem o-rings:** rubber
- Sleeve:** brass
- Nut:** brass

DIMENSIONS

	-G2C1C	-G2C0C	-G1C1C	-G2X1C	-G2X0C	-G2W1C	-G2W0C	-G2V1C	-G2S1C	-G2F1C	-G1F1C	-G1RETRO
A: overall length	2.377"	2.379"	2.175"	2.157"	2.154"	2.371"	2.237"	2.639"	2.022"	2.383"	2.326"	2.334"
B: overall height	1.518"	1.534"	1.399"	1.399"	1.399"	1.399"	1.399"	1.515"	1.399"	1.524"	1.427"	1.399"
C: overall width	1.075"	1.075"	0.815"	0.815"	0.815"	0.815"	0.815"	1.077"	0.815"	1.077"	0.900"	0.815"

ITEM # SUBMITTED _____
JOB NAME _____
LOCATION _____
ENGINEER _____
CONTRACTOR _____
PO# _____ TAG _____



129-G1RETRO

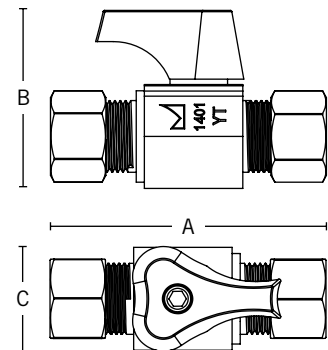

Create Item Number

129-GAB

e.g. 129-G2W1C: 1/2" PEX F1960 Grip™ × 3/8" compression straight quarter-turn supply stop

INLET CONNECTION A

- 1C = 3/8" compression
- 2C = 5/8" compression
- 2X = 1/2" PEX F1807 Crimp™
- 2W = 1/2" PEX F1960 Grip™
- 2V = 1/2" CPVC¹
- 2S = 1/2" sweat¹
- 1F = 3/8" FIP¹
- 2F = 1/2" FIP¹

1RETRO = retrofit 3/8" female
compression × 3/8" compression²

OUTLET CONNECTION B

- OC = 1/4" compression
- 1C = 3/8" compression

¹ 3/8" compression outlet only

² Leave outlet blank for retrofit stops